

ISW ISWR ISWH ISWB 系列

单级单吸卧式离心泵

DAN JI DAN XI WO SHI LI XI BENG

◀ 使用说明书 ▶

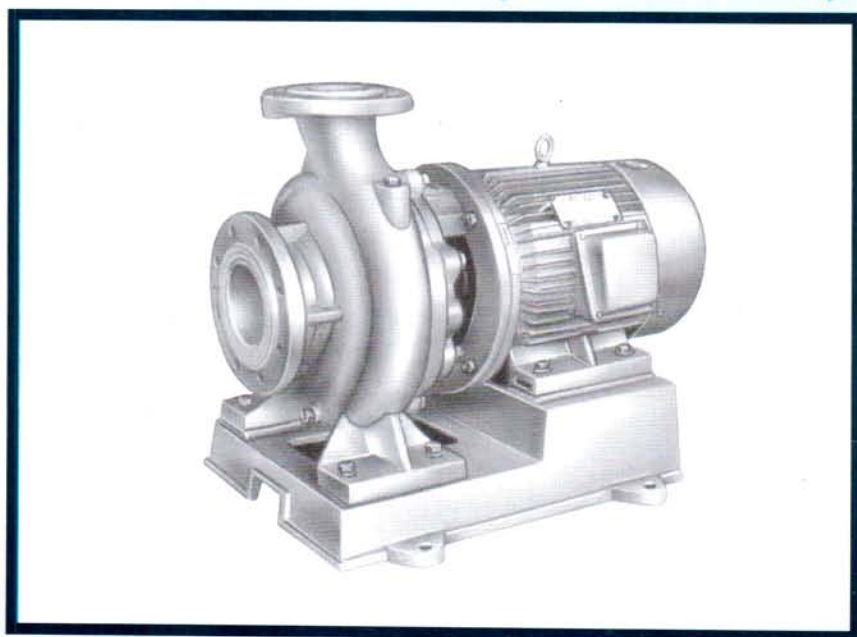

上海阳光泵业制造有限公司

SHANGHAI YANGGUANG PUMP MFG.CO.,LTD.

目 录

1、产品概述	1
2、产品特点	1
3、型号意义	1
4、用途	2
5、工作条件	2
6、结构说明	2
7、主要性能参数表	3~6
8、性能谱图	7
9、安装方式	7
10、外形安装尺寸表	8~11
11、主要材质及选用	12
12、安装说明	12
13、起动与停车	13
14、泵与维护	14
15、主要材质及选用	14
16、易损件	15
17、故障原因及排除方法	15
18、管路损耗参考表	16

产品概述

ISW型单级单吸卧式离心泵。采用最先进的水力模型，根据IS型离心泵之性能参数和立式泵的独特结构组合设计，并严格按照国际标准ISO2858进行设计制造，该产品轴封选用硬质合金机械密封装置，具有高效节能、性能可靠、安装使用方便等特点。

产品特点

运行平稳：泵轴的绝对同心度及叶轮优异的动静平衡，保证平稳运行，绝无振动。

滴水不漏：不同材质的硬质合金密封，保证了不同介质输送均无泄漏。

噪音低：两个低噪音轴承支撑下的水泵，运转平稳，除电机微弱声响，基本无噪音。

故障率低：结构简单合理，关键部分采用国际一流品质配套，整机无故障工作时间大大提高。

维修方便：更换密封、轴承，简易方便。

占地更省：出口可向左、向右、向上三个方向，便于管道布置安装，节省空间。

型号意义

ISW 80-160 (I) (A) (B) (C)

叶轮经第三次切割

叶轮经第二次切割

叶轮经第一次切割

流量分类

叶轮名义直径(mm)

泵进、出口公称直径(mm)

ISW卧式清水泵

ISWR卧式热水泵

ISWH卧式化工泵

ISWB卧式管道油泵

用 途

- 1、ISW卧式清水泵，供输送清水及物理化学性质类似于清水的其他液体之用，适用于工业和城市给排水，高层建筑增压送水，园林喷灌，消防增压，远距离输送，暖通制冷循环、浴室等增压及设备配套，使用温度 $T \leq 80^{\circ}\text{C}$ 。
- 2、ISWR卧式热水泵广泛适用于：冶金、化工、纺织、造纸、以及宾馆饭店等锅炉热水增压、输送、及城市采暖系统，SGWR型使用温度 $T \leq 120^{\circ}\text{C}$ 。
- 3、ISWH卧式化工泵，供输送不含固体颗粒，具有腐蚀性，粘度类似于水的液体，适用于石油、化工、冶金、电力、造纸、食品制药和合成纤维等部门，使用温度为 $-20^{\circ}\text{C} \sim +120^{\circ}\text{C}$ 。
- 4、ISWB卧式管道油泵，供输送汽油、煤油、柴油等油类产品或易燃、易爆液体，被输送介质温度为 $-20^{\circ}\text{C} \sim +120^{\circ}\text{C}$ 。

工作条件

- 1、吸入压力 $\leq 1.0\text{MPa}$ ，或泵系统最高工作压力 $\leq 1.6\text{MPa}$ ，即泵吸入口压力+泵扬程 $\leq 1.6\text{MPa}$ 、泵静压试验压力为 2.5MPa ，订货时请注明系统工作压力。泵系统工作压力大于 1.6MPa 时应在订货时另行提出。以便在制造时泵的过流部分和联接部分采用铸钢材料。
- 2、环境温度 $< 40^{\circ}\text{C}$ ，相对湿度 $< 95\%$ 。
- 3、所输送介质中固体颗粒体积含量不超过单位体积的 0.1% ，粒度 $< 0.2\text{mm}$ 。

注：如使用介质为带有细小颗粒，请在订货时注明，以便厂家采用耐磨式机械密封。

结构说明

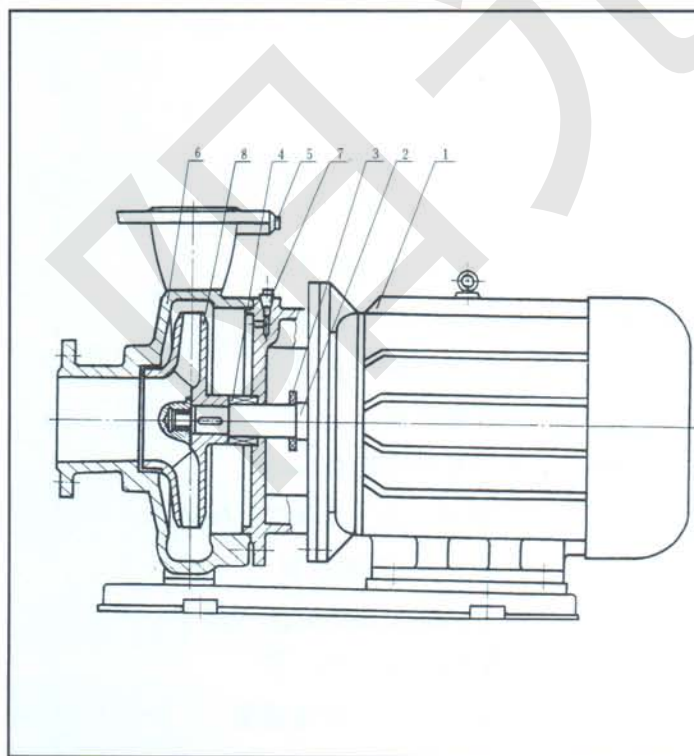

1	电动机：直接与水泵联接传递动力，采用名牌电机。
2	泵轴：与电机同轴，为电机加长轴，确保了轴的同心，使泵运行平稳、无噪音和振动现象，采用镀铬处理，增强了使用寿命。
3	挡水圈：防止因密封漏水而使电机进水。
4	机械密封：采用不锈钢、碳化钨、氟橡胶等材料制成。平衡式耐高温、高压机械密封，运行寿命长，不渗漏，对轴无磨损，不积水垢，保证工作环境的整洁。
5	取压塞：可安装压力表直观监控泵的正常高效运行
6	泵体：压出室和吸入室采用优秀水力模型设计而成，既美观又高效，设有安装底脚，便于安装和运行稳固。
7	放气塞：灌泵时排净泵内空气，保证了泵的正常启动。
8	叶轮：采用先进的水力模型设计而成，具有高效率，可靠性好等特点。

ISW、ISWR、ISWH、ISWB系列泵性能表

序号	型号	流量 Q		扬程 (m)	效率 (%)	转速 (r/min)	电机功率 (kW)	必需汽蚀余量 (m)	序号	型号	流量 Q		扬程 (m)	效率 (%)	转速 (r/min)	电机功率 (kW)	必需汽蚀余量 (m)
		(m³/h)	(l/s)								(m³/h)	(l/s)					
1	15-80	1.1	0.3	8.5	26	2800	0.18	2.3	28	40-160(I)	8.8	2.44	33	45	2900	3.0	2.3
		1.5	0.42	8	34						12.5	3.47	32	52			
		2.0	0.55	7	34						16.3	4.53	30	51			
2	20-110	1.8	0.5	16	25	2800	0.37	2.3	29	40-160(I)A	8.2	2.28	29	44	2900	2.2	2.3
		2.5	0.69	15	34						11.7	3.25	28	51			
		3.3	0.91	13.5	35						15.2	4.22	26	50			
3	20-160	1.8	0.5	33	19	2900	1.1	2.3	30	40-160(I)B	7.3	2.38	23	42	2900	1.5	2.3
		2.5	0.69	32	25						10.4	2.89	22	49			
		3.3	0.91	30	23						13.5	3.75	20.5	47			
4	25-110	2.8	0.78	16	34	2900	0.55	2.3	31	40-200(I)	8.8	2.44	51.2	38	2900	5.5	2.3
		4	1.11	15	42						12.5	3.47	50	46			
		5.2	1.44	13.5	41						16.3	4.53	48	46			
5	25-125	2.8	0.78	20.6	28	2900	0.75	2.3	32	40-200(I)A	8.3	2.31	45	37	2900	4	2.3
		4	1.11	20	36						11.7	3.25	44	45			
		5.2	1.44	18	35						15.3	4.25	42	45			
6	25-125A	2.5	0.69	17	27	2800	0.55	2.3	33	40-200(I)B	7.5	2.08	37	35	2900	3	2.3
		3.6	1.0	16	35						10.6	2.94	36	44			
		4.6	1.28	14.4	34						13.8	3.83	34	42			
7	25-160	2.8	0.78	33	24	2900	1.5	2.3	34	40-250(I)	8.8	2.44	81.2	31	2900	11	2.3
		4	1.11	32	32						12.5	3.47	80	38			
		5.2	1.44	30	33						16.3	4.53	77.5	40			
8	25-160A	2.6	0.72	29	22	2900	1.1	2.3	35	40-250(I)A	8.2	2.28	71	28	2900	7.5	2.3
		3.7	1.03	28	31						11.6	3.22	70	38			
		4.9	1.36	26	32						15.2	4.22	68	39			
9	32-125	3.5	0.97	22	40	2900	0.75	2.3	36	40-250(I)B	7.6	2.11	61.4	28	2900	7.5	2.3
		5	1.39	20	44						10.8	3.0	60	37			
		6.5	1.8	18	42						14	3.89	58	37			
10	32-125A	3.1	0.86	17.6	38	2900	0.55	2.3	37	40-250(I)C	7.1	1.97	53.2	26	2900	5.5	2.3
		4.5	1.25	16	42						10.0	2.78	52	36			
		5.8	1.61	14.4	40						13.1	3.64	50.4	35			
11	40-100	4.4	1.22	13.2	48	2900	0.55	2.3	38	50-100	8.8	2.44	13.6	55	2900	1.1	2.3
		6.3	1.75	12.5	54						12.5	3.47	12.5	62			
		8.3	2.31	11.3	53						16.3	4.53	11.3	60			
12	40-100A	3.9	1.08	10.6	45	2900	0.37	2.3	39	50-100A	8	2.22	11	52	2900	0.75	2.3
		5.6	1.56	10	52						11	3.05	10	60			
		7.4	2.06	9	50						14.5	4.03	9	56			
13	40-125	4.4	1.22	21	41	2900	1.1	2.3	40	50-125	8.8	2.44	21.5	49	2900	1.5	2.3
		6.3	1.75	20	46						12.5	3.47	20	58			
		8.3	2.31	18	43						16.3	4.53	17.8	57			
14	40-125A	3.9	1.08	17.6	40	2900	0.75	2.3	41	50-125A	8	2.22	17	47	2900	1.1	2.3
		5.6	1.56	16	45						11	3.05	16	57			
		7.4	2.06	14.4	41						14.5	4.03	14	54			
15	40-160	4.4	1.22	33	35	2900	2.2	2.3	42	50-160	8.8	2.44	33	45	2900	3	2.3
		6.3	1.75	32	40						12.5	3.47	32	52			
		8.3	2.31	30	40						16.3	4.53	30	51			
16	40-160A	4.1	1.44	29	34	2900	1.5	2.3	43	50-160A	8.2	2.28	29	44	2900	2.2	2.3
		5.9	1.64	28	39						11.7	3.25	28	51			
		7.8	2.17	26.3	39						15.2	4.22	26	50			
17	40-160B	3.8	1.06	25.5	34	2900	1.1	2.3	44	50-160B	7.3	2.38	23	42	2900	1.5	2.3
		5.5	1.53	24	38						10.4	2.89	22	49			
		7.2	2.0	22.5	37						13.5	3.75	20.5	47			
18	40-200	4.4	1.22	51	26	2900	4	2.3	45	50-200	8.8	2.44	52	38	2900	5.5	2.3
		6.3	1.75	50	33						12.5	3.47	50	46			
		8.3	2.31	48	32						16.3	4.53	48	46			
19	40-200A	4.1	1.14	45	26	2900	3	2.3	46	50-200A	8.3	2.31	45.8	37	2900	4	2.3
		5.9	1.64	44	31						11.7	3.25	44	45			
		7.8	2.17	42	30						15.3	4.25	42	45			
20	40-200B	3.7	1.03	38	23	2900	2.2	2.3	47	50-200B	7.5	2.08	37	35	2900	3	2.3
		5.3	1.47	36	29						10.6	2.94	36	44			
		7.0	1.94	34.5	27						13.8	3.83	34	42			
21	40-250	4.4	1.22	82	24	2900	7.5	2.3	48	50-250	8.8	2.44	82	29	2900	11	2.3
		6.3	1.75	80	28						12.5	3.47	80	28			
		8.3	2.31	74	28						16.3	4.53	77.5	40			
22	40-250A	4.1	1.14	72	24	2900	5.5	2.3	49	50-250A	8.2	2.28	71.5	28	2900	7.5	2.3
		5.9	1.64	70	28						11.6	3.22	70	38			
		7.8	2.17	65	27						15.2	4.22	68	39			
23	40-250B	3.8	1.06	61.5	23	2900	4	2.3	50	50-250B	7.6	2.11	61.4	28	2900	7.5	2.3
		5.5	1.53	60	27						10.8	3.0	60	37			
		7.0	1.94	56	26						14	3.89	58	37			
24	40-100(I)	8.8	2.44	13.2	55	2900	1.1	2.3	51	50-250C	7.1	1.97	53.2	26	2900	5.5	2.3
		12.5	3.47	12.5	62						10.0	2.78	52	36			
		16.3	4.53	11.3	60						13.1	3.64	50.4	35			
25	40-100(I)A	8	2.22	10.6	52	2900	0.75	2.3	52	50-100(I)	17.5	4.86	13.7	67	2900	1.5	2.5
		11	3.05	10	60						25	6.94	12.5	69			
		14.5	4.03	9	56						32.5	9.03	10.5	69			
26	40-125(I)	8.8	2.44	21.2	49	2900	1.5	2.3	53	50-100(I)A	15.6	4.3	11	65	2900	1.1	2.5
		12.5	3.47	20	58						22.3	6.19	10	67			
		16.3	4.53	17.8	57						29	8.1	8.4	68			
27	40-125(I)A	8	2.22	17	47	2900	1.1	2.3	54	50-125(I)	17.5	4.86	21.5	60	2900	3	2.5
		11	3.05	16	57						25	6.94	20	68			
		14.5	4.03	14	54						32.5	9.03	18	67			

ISW、ISWR、ISWH、ISWB系列泵性能表

序号	型号	流量 Q		扬程 (m)	效率 (%)	转速 (r/min)	电机功率 (kW)	必需汽蚀余量 (m)	序号	型号	流量 Q		扬程 (m)	效率 (%)	转速 (r/min)	电机功率 (kW)	必需汽蚀余量 (m)
		(m³/h)	(l/s)								(m³/h)	(l/s)					
55	50-125(I)A	15.6	4.33	17	58	2900	2.2	2.5	82	65-315	17.5	4.86	127	32	2900	30	2.5
		22.3	6.19	16	66						25	6.94	125	40			
		29	8.1	13.6	65						32.5	9.03	122	44			
56	50-160(I)	17.5	4.86	34.4	54	2900	4	2.5	83	65-315A	16.6	4.61	115	32	2900	22	2.5
		25	6.94	32	63						23.7	6.58	113	40			
		32.5	9.03	27.5	60						31	8.6	110	44			
57	50-160(I)A	16.4	4.56	30	54	2900	4	2.5	84	65-315B	15.7	4.36	103	30	2900	22	2.5
		23.4	6.5	28	62						22.5	6.25	101	39			
		30.4	8.44	24	59						29.2	8.0	98	42			
58	50-160(I)B	15.0	4.17	26	49	2900	3	2.5	85	65-315C	14.4	4.0	86	28	2900	15	2.5
		21.6	6.0	24	58						20.6	5.72	85	38			
		28	7.78	20.6	54						26.8	7.44	83	40			
59	50-200(I)	17.5	4.86	52.7	49	2900	7.5	2.5	86	65-100(I)	35	9.72	13.8	67	2900	3	3.0
		25	6.94	50	58						50	13.9	12.5	73			
		32.5	9.03	45.5	59						65	18.1	10	70			
60	50-200(I)A	16.4	4.56	46.4	48	2900	7.5	2.5	87	65-100(I)A	31.3	8.7	11	66	2900	2.2	3.0
		23.5	6.53	44	57						44.7	12.4	10	72			
		30.5	8.47	40	58						58	16.1	8	69			
61	50-200(I)B	15.2	4.22	40	45	2900	5.5	2.5	88	65-125(I)	35	9.72	22	67	2900	5.5	3.0
		21.8	6.06	38	55						50	13.9	20	72.5			
		28.3	7.86	34.5	55						65	18.1	17	70			
62	50-250(I)	17.5	4.86	82	39	2900	15	2.5	89	65-125(I)A	31.3	8.7	17.5	66	2900	4	3.0
		25	6.94	80	50						45	12.5	16	71			
		32.5	9.03	76.5	52						58	16.1	13.6	69			
63	50-250(I)A	16.4	4.56	71.5	39	2900	11	2.5	90	65-160(I)	35	9.72	35	63	2900	7.5	3.0
		23.4	6.5	70	50						50	13.9	32	71			
		30.5	8.47	67	52						65	18.1	28	70			
64	50-250(I)B	15	4.17	61	38	2900	11	2.5	91	65-160(I)A	32.7	9.1	30.6	62	2900	7.5	3.0
		21.6	6.0	60	49						46.7	13.0	28	70			
		28	7.78	57.4	54						61	16.9	24	69			
65	50-315(I)	17.5	4.86	128	30	2900	30	2.5	92	65-160(I)B	30.3	8.4	26	60	2900	5.5	3.0
		25	6.94	125	40						43.3	12.0	24	69			
		32.5	9.03	122	44						56.3	15.6	21	67			
66	50-315(I)A	16.6	4.61	115	30	2900	22	2.5	93	65-200(I)	35	9.72	53.5	55	2900	15	3.0
		23.7	6.58	113	40						50	13.9	50	67			
		31	8.6	110	44						65	18.1	46	68			
67	50-315(I)B	15.7	4.36	103	30	2900	22	2.5	94	65-200(I)A	32.8	9.1	47	54	2900	11	3.0
		22.5	6.25	101	39						47	13.1	44	66			
		29.2	8.0	98	42						61	16.9	40	67			
68	50-315(I)C	14.4	4.0	86	38	2900	15	2.5	95	65-200(I)B	30.5	8.5	40.6	52	2900	7.5	3.0
		20.6	5.72	85	48						43.5	12.1	38	65			
		26.8	7.44	83	40						56.6	15.7	33.4	65			
69	65-100	17.5	4.86	13.7	67	2900	1.5	2.5	96	65-250(I)	35	9.72	83	52	2900	22	3.0
		25	6.94	12.5	69						50	13.9	80	59			
		32.5	9.03	10.5	69						65	18.1	72	60			
70	65-100A	15.6	4.3	11	65	2900	1.1	2.5	97	65-250(I)A	32.5	9.0	73	52	2900	18.5	3.0
		22.3	6.19	10	67						46.7	13.0	70	59			
		29	8.1	8.4	68						61	16.9	63	60			
71	65-125	17.5	4.86	21.5	60	2900	3	2.5	98	65-250(I)B	30	8.3	62	50	2900	15	3.0
		25	6.94	20	68						43.3	12.0	60	58			
		32.5	9.03	18	67						56	15.6	54	58			
72	65-125A	15.6	4.33	17	58	2900	2.2	2.5	99	65-315(I)	35	9.72	128	44	2900	37	3.0
		22.3	6.19	16	66						50	13.9	125	54			
		29	8.1	14.4	65						65	18.1	121	57			
73	65-160	17.5	4.86	34.4	54	2900	4	2.5	100	65-315(I)A	32.5	9.0	112.6	43	2900	37	3.0
		25	6.94	32	63						46.5	12.9	110	54			
		32.5	9.03	27.5	60						60.5	16.8	106.4	57			
74	65-160A	16.4	4.56	30	54	2900	4	2.5	101	65-315(I)B	31	8.6	102.5	41	2900	30	3.0
		23.4	6.5	28	63						44.5	12.4	100	53			
		30.4	8.44	24	59						58	16.1	98	55			
75	65-160B	15.0	4.17	26	49	2900	3	2.5	102	65-315(I)C	29	8.0	98	38	2900	22	3.0
		21.6	6.0	24	58						41	11.4	85	50			
		28	7.78	20.6	54						53.6	14.9	83	52			
76	65-200	17.5	4.86	52.7	49	2900	7.5	2.5	103	80-100	35	9.72	13.8	67	2900	3	3.0
		25	6.94	50	58						50	13.9	12.5	73			
		32.5	9.03	45.5	59						65	18.1	10	70			
77	65-200A	16.4	4.56	46.4	48	2900	7.5	2.5	104	80-100A	31.3	8.7	11	66	2900	2.2	3.0
		23.5	6.53	44	57						44.7	12.4	10	72			
		30.5	8.47	40	58						58	16.1	8	69			
78	65-200B	15.2	4.22	40	45	2900	5.5	2.5	105	80-125	35	9.72	22	67	2900	5.5	3.0
		21.8	6.06	38	55						50	13.9	20	72.5			
		28.3	7.86	34.5	55						65	18.1	17	70			
79	65-250	17.5	4.86	82	39	2900	15	2.5	106	80-125A	31.3	8.7	17.5	66	2900	4	3.0
		25	6.94	80	50						45	12.5	16	71			
		32.5	9.03	76.5	52						58	16.1	13.6	69			
80	65-250A	16.4	4.56	71.5	39	2900	11	2.5	107	80-160	35	9.72	35	63	2900	7.5	3.0
		23.4	6.5	70	50						50	13.9	32	71			
		30.5	8.47	67	52						65	18.1	28	70			
81	65-250B	15	4.17	61	38	2900	11	2.5	108	80-160A	32.7	9.1	30.6	62	2900	7.5	3.0
		21.6	6.0	60	49						46.7	13.0	28	70			
		28	7.78	57.4	54						61	16.9	24	69			

ISW、ISWR、ISWH、ISWB系列泵性能表

序号	型号	流量 Q		扬程 (m)	效率 (%)	转速 (r/min)	电机功率 (kW)	必需汽蚀余量 (m)	序号	型号	流量 Q		扬程 (m)	效率 (%)	转速 (r/min)	电机功率 (kW)	必需汽蚀余量 (m)
		(m³/h)	(l/s)								(m³/h)	(l/s)					
109	80-160B	30.3	8.4	26	60	2900	5.5	3.0	138	100-100A	62.6	17.4	11	64	2900	4	4.5
		43.3	12.0	21	69						10	74					
		56.3	15.6	24	67						8.8	74					
110	80-200	35	9.72	53.5	55	2900	15	3.0	139	100-125	70	19.4	23.5	70	2900	11	4.5
		50	13.9	50	67						20	76					
		65	18.1	46	68						14	65					
111	80-200A	32.8	9.1	47	55	2900	11	3.0	140	100-125A	62.6	17.4	19	68	2900	7.5	4.5
		47	13.1	44	66						16	74					
		61	16.9	40	67						11	63					
112	80-200B	30.5	8.5	40.6	52	2900	7.5	3.0	141	100-160	70	19.4	36.5	70	2900	15	4.5
		43.5	12.1	38	65						32	76					
		56.6	15.7	33.4	65						24	65					
113	80-250	35	9.72	83	52	2900	22	3.0	142	100-160A	65.4	18.2	32	68	2900	11	4.5
		50	13.9	80	59						28	74					
		65	18.1	72	60						21	67					
114	80-250A	32.5	9.03	73	52	2900	18.5	3.0	143	100-160B	60.6	16.8	27	66	2900	11	4.5
		46.7	13.0	70	59						24	72					
		61	16.9	63	60						18	64					
115	80-250B	30	8.3	62	50	2900	15	3.0	144	100-200	70	19.4	54	65	2900	22	4.0
		43.3	12.0	60	58						50	74					
		56	15.6	54	58						42	73					
116	80-315	35	9.72	128	43	2900	37	3.0	145	100-200A	65.4	18.2	47.5	64	2900	18.5	4.0
		50	13.9	125	54						44	73					
		65	18.1	122	57						37	72					
117	80-315A	32.5	9.03	112.6	43	2900	37	3.0	146	100-200B	61	16.9	41	62	2900	15	4.0
		46.5	12.9	110	54						38	71					
		60.5	16.8	107.4	57						32	69					
118	80-315B	31	8.6	102.5	41	2900	30	3.0	147	100-250	70	19.4	87	62	2900	37	4.0
		44.5	12.4	100	53						80	69					
		58	16.1	98	55						68	68					
119	80-315C	29	8.1	87	39	2900	22	3.0	148	100-250A	65.4	18.2	76	61	2900	30	4.0
		41	11.4	85	51						70	68					
		53.6	14.9	83	51						59.5	67					
120	80-100(I)	70	19.4	13.6	66	2900	5.5	4.5	149	100-250B	61	16.9	65.8	59	2900	30	4.0
		100	27.8	12.5	76						60.5	68					
		130	36.1	11	75						51.4	66					
121	80-100(I)A	62.6	17.4	11	64	2900	4	4.5	150	100-315	70	19.4	132	55	2900	75	4.0
		89	24.7	10	74						125	66					
		116	32.2	8.8	74						114	67					
122	80-125(I)	70	19.4	23.5	70	2900	11	4.5	151	100-315A	66.5	18.5	119	55	2900	55	4.0
		100	27.8	20	76						113	66					
		130	36.1	14	65						103	67					
123	80-125(I)A	62.6	17.4	19	68	2900	7.5	4.5	152	100-315B	63	17.5	106.6	54	2900	45	4.0
		89	24.7	16	74						101	65					
		116	32.2	11	63						92	66					
124	80-160(I)	70	19.4	36.5	70	2900	15	4.5	153	100-315C	58	16.1	90	51	2900	37	4.0
		100	27.8	32	76						85	63					
		130	36.1	24	65						76	63					
125	80-160(I)A	65.4	18.2	32	68	2900	11	4.5	154	125-100	96	26.7	13	63	2900	11	4.0
		93.5	26.0	28	74						44.4	80					
		121.6	33.8	21	67						53.3	76					
126	80-160(I)B	60.6	16.8	27	65	2900	11	4.5	155	125-100A	86	23.9	10.4	60	2900	7.5	4.0
		86.6	24.1	24	72						39.7	10					
		112.5	31.3	18	64						47.8	9.6					
127	80-200(I)	70	19.4	54	65	2900	22	4.0	156	125-125	96	26.7	22.6	62	2900	15	4.0
		100	27.8	50	74						20	78					
		130	36.1	42	73						17	78					
128	80-200(I)A	65.4	18.2	47.5	64	2900	18.5	4.0	157	125-125A	86	23.9	18	60	2900	11	4.0
		93.5	26.0	44	73						16	76					
		121.6	33.8	37	72						13.6	76					
129	80-200(I)B	61	16.9	41	61	2900	15	4.0	158	125-160	96	26.7	36	64	2900	22	4.0
		87	24.2	38	71						32	78					
		113	31.4	32	69						28	66					
130	80-250(I)	70	19.4	87	62	2900	37	4.0	159	125-160A	90	25	31.5	62	2900	18.5	4.0
		100	27.8	80	69						41.7	28					
		130	36.1	68	68						50	64					
131	80-250(I)A	65.4	18.2	76	61	2900	30	4.0	160	125-160B	83	21.7	27	58	2900	15	4.0
		93.5	26.0	70	68						38.3	24					
		121.6	33.8	59.5	67						46.1	21					
132	80-250(I)B	61	16.9	65	58	2900	30	4.0	161	125-200	96	26.7	55	65	2900	37	5.5
		87	24.2	60	66						50	77					
		113	31.4	51	64						46	76					
133	80-315(I)	70	19.4	132	55	2900	75	4.0	162	125-200A	90	25	48.4	63	2900	30	5.5
		100	27.8	125	66						41.7	44					
		130	36.1	114	67						50	40.5					
134	80-315(I)A	66.5	18.5	119	55	2900	55	4.0	163	125-200B	83	21.7	41.3	61	2900	22	5.5
		95	26.4	113	66						38.3	37.5					
		123.6	34.3	103	67						46.1	34.5					
135	80-315(I)B	63	17.5	106.6	52	2900	45	4.0	164	125-250	96	26.7	87	61	2900	55	5.0
		90	25	101	64						44.4	80					
		117	32.5	92	64						53.3	73					
136	80-315(I)C	58	16.1	90	50	2900	37	4.0	165	125-250A	90	25	76	60	2900	45	5.0
		82	22.8	85	62						41.7	70					
		107	29.7	76	61						50	71					
137	100-100	70	19.4	13.6	66	2900	5.5	4.5	166	125-250B	83	21.7	65	58	2900	37	5.0
		100	27.8	12.5	76						60	72					
		130	36.1	11	75						55	68					

ISW、ISWR、ISWH、ISWB系列泵性能表

序号	型号	流量 Q		扬程 (m)	效率 (%)	转速 (r/min)	电机功率 (kW)	必需汽蚀余量 (m)	序号	型号	流量 Q		扬程 (m)	效率 (%)	转速 (r/min)	电机功率 (kW)	必需汽蚀余量 (m)
		(m³/h)	(l/s)								(m³/h)	(l/s)					
167	125-315	96 160 192	26.7 44.7 53.3	133 125 119	55 70 72	2900	90	5.0	196	200-315B	121 173 225	33.6 48.1 62.5	25 24 21	67 75 74	1450	18.5	3.5
168	125-315A	90 150 180	25 41.7 50	117 110 104.6	54 69 71	2900	75	5.0	197	200-400	140 200 260	38.9 55.6 72.2	53 50 44	68 75 71	1450	45	3.5
169	125-315B	86 143 172	23.9 39.7 47.8	106.4 100 95.2	53 68 70	2900	75	5.0	198	200-400A	131 187 243	36.4 51.9 67.5	46.6 44 38.3	67 74 70	1450	37	3.5
170	125-315C	80.5 134 161	22.4 37.2 44.7	93.3 87.7 83.5	50 65 66	2900	55	5.0	199	200-400B	122 174 226.5	33.9 48.3 62.9	40 38 33	66 73 68	1450	30	3.5
171	150-200	140 200 260	38.9 55.6 72.2	13.8 12.5 10.6	68 78 78	1450	15	3.0	200	200-400C	112 160 208	31.3 44.4 57.8	34 32 28	63 71 65	1450	22	3.5
172	150-200A	125 179 232.5	34.7 49.7 64.6	11 10 8.5	66 76 76	1450	11	3.0	201	200-200(I)	280 400 520	77.8 111.1 144	13.4 12.5 10.5	70 80 79	1450	22	4.0
173	150-250	140 200 260	38.9 55.6 72.2	21.8 20 17	73 79 77	1450	18.5	3.0	202	200-200(I)A	250 358 465	69.4 99.4 129.2	10.7 10 8.5	68 78 77	1450	18.5	4.0
174	150-250A	129 184.4 240	35.8 51.2 66.7	18.5 17 14.4	72 78 76	1450	15	3.0	203	200-250(I)	280 400 520	77.8 111.4 144	22.2 20 14	75 80 72	1450	30	4.0
175	150-250B	117 167 217.5	32.5 46.4 60.4	15.2 13.9 11.8	70 76 73	1450	11	3.0	204	200-250(I)A	250 358 465	69.4 99.4 129.2	18 16 11.2	73 78 70	1450	22	4.0
176	150-315	140 200 260	38.9 55.6 72.2	33.8 32 28	70 78 73	1450	30	3.5	205	200-250(I)B	226 322 419	62.8 89.4 116.4	14.4 13 7.3	70 75 67	1450	18.5	4.0
177	150-315A	131 187 243	36.4 51.9 67.5	29.5 28 24.5	69 77 77	1450	22	3.5	206	200-315(I)	280 400 520	77.8 111.4 144	36 32 26	73 80 75	1450	55	4.0
178	150-315B	121 173 225	33.6 48.1 62.5	25 24 21	60 75 69	1450	18.5	3.5	207	200-315(I)A	262 374 486	72.8 103.9 135	31.5 28 23	72 79 74	1450	45	4.0
179	150-400	140 200 260	38.9 55.6 72.2	53 50 44	68 75 71	1450	45	3.5	208	200-315(I)B	242 346 450	67.2 96.1 125	27 24 19.5	70 77 71	1450	37	4.0
180	150-400A	131 187 243	36.4 51.9 67.5	46.6 4 38.3	67 74 70	1450	37	3.5	209	200-400(I)	280 400 520	77.8 111.4 144	54.5 50 39	75 81 77	1450	75	4.0
181	150-400B	122 174 226.5	33.9 48.3 62.9	40 38 33	66 73 68	1450	30	3.5	210	200-400(I)A	262 374 486	72.8 103.9 135	47.6 43.7 34.1	74 80 76	1450	75	4.0
182	150-400C	112 160 208	31.1 44.4 57.8	34 32 28	64 71 65	1450	22	3.5	211	200-400(I)B	242 346 450	67.2 96.1 125	40.8 37.4 29.2	72 78 74	1450	55	5.0
183	150-250(I)	120 200 240	33.3 55.6 66.7	87 80 74	65 76 74	2900	75	4.5	212	200-400(I)C	224 320 416	62.2 88.9 115.6	34.9 32 25	70 76 71	1450	45	5.0
184	150-250(I)A	112 187 224	31.1 51.9 62.2	76 70 63	64 75 73	2900	55	4.5	213	300-235	480 720 900	133.3 200 250	20 18 15.5	77 81 74	970	55	5.0
185	150-250(I)B	104 173 208	28.9 48.1 57.8	65 60 54	63 74 72	2900	45	4.5	214	300-235A	438 657 821	121.7 182.5 228.1	16.7 15 12.9	75 79 72	970	45	5.0
186	150-315(I)	120 200 240	33.3 55.6 66.7	133 125 120	58 73 75	2900	110	4.5	215	300-235B	400 600 750	111.1 167.0 208.3	13.9 12.5 10.8	73 77 70	970	37	5.0
187	150-315(I)A	112 187 224	31.1 51.9 62.2	116 110 105	57 72 74	2900	90	4.5	216	300-300	480 720 900	133.3 200 250	31 28 25	77 81 77	970	75	5.0
188	150-315(I)B	104 173 208	28.9 48.1 57.8	100 95 91	55 70 72	2900	75	4.5	217	300-300A	444 666 833	123.3 185 231.4	26.5 24 21.4	76 80 76	970	75	5.0
189	200-200	140 200 260	38.9 55.6 72.2	13.8 12.5 10.6	68 78 78	1450	15	3.0	218	300-300B	415 623 779	115.3 173.1 216.4	23 21 18.5	74 78 73	970	55	5.0
190	200-200A	125 179 232.5	34.7 49.7 64.6	11 10 8.5	66 76 76	1450	11	3.0	219	300-380	480 720 900	133.3 200 250	48 44 34	75 84 79	970	132	5.0
191	200-250	140 200 260	38.9 55.6 72.2	21.8 20 17	73 79 77	1450	18.5	3.0	220	300-380A	444 666 833	123.3 185 231.4	41.4 37.6 29.1	74 82 79	970	110	5.0
192	200-250A	129 184.4 240	35.8 51.2 66.7	18.5 17 14.4	72 78 76	1450	15	3.0	221	300-380B	409 614 767	113.6 170.6 213.1	35 32 25	72 78 76	970	90	5.0
193	200-250B	117 167 217.5	32.5 46.4 60.4	15.2 14 12	70 76 73	1450	11	3.0	222	300-235(I)	718 1080	199.4 300	44.6 40	78 82	1450	160	7.5
194	200-315	140 200 260	38.9 55.6 72.2	33.8 32 28	70 78 78	1450	30	3.5	223	300-235(I)A	642 965 1203	178.3 268.1 334.2	35.7 32 27.7	73 80 74	1450	132	7.5
195	200-315A	131 187 243	36.4 51.9 67.5	29.5 28 24.5	69 77 77	1450	22	3.5									

ISW、ISWR、ISWH、ISWB系列泵型谱图

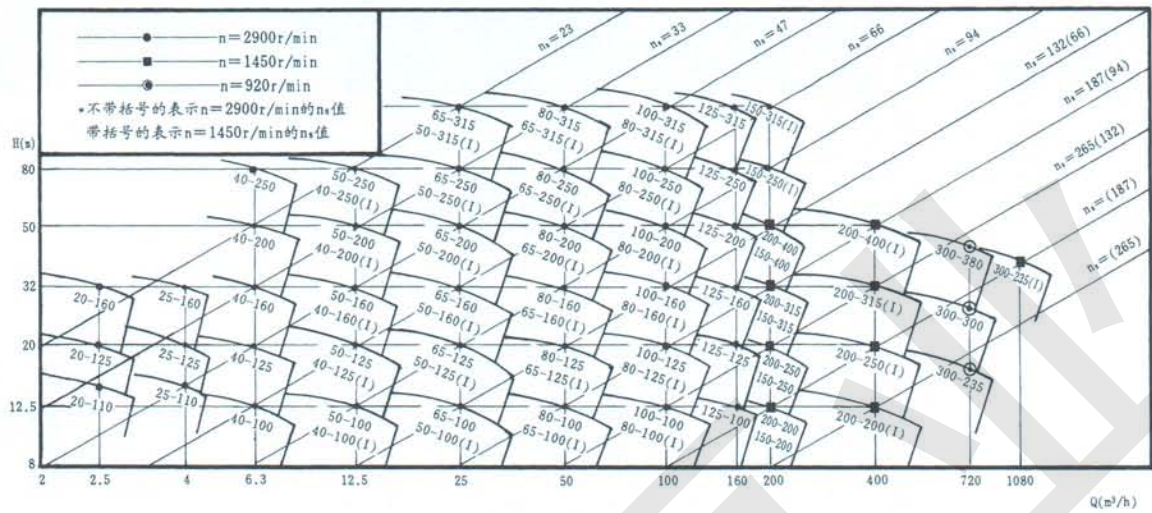

安装方式

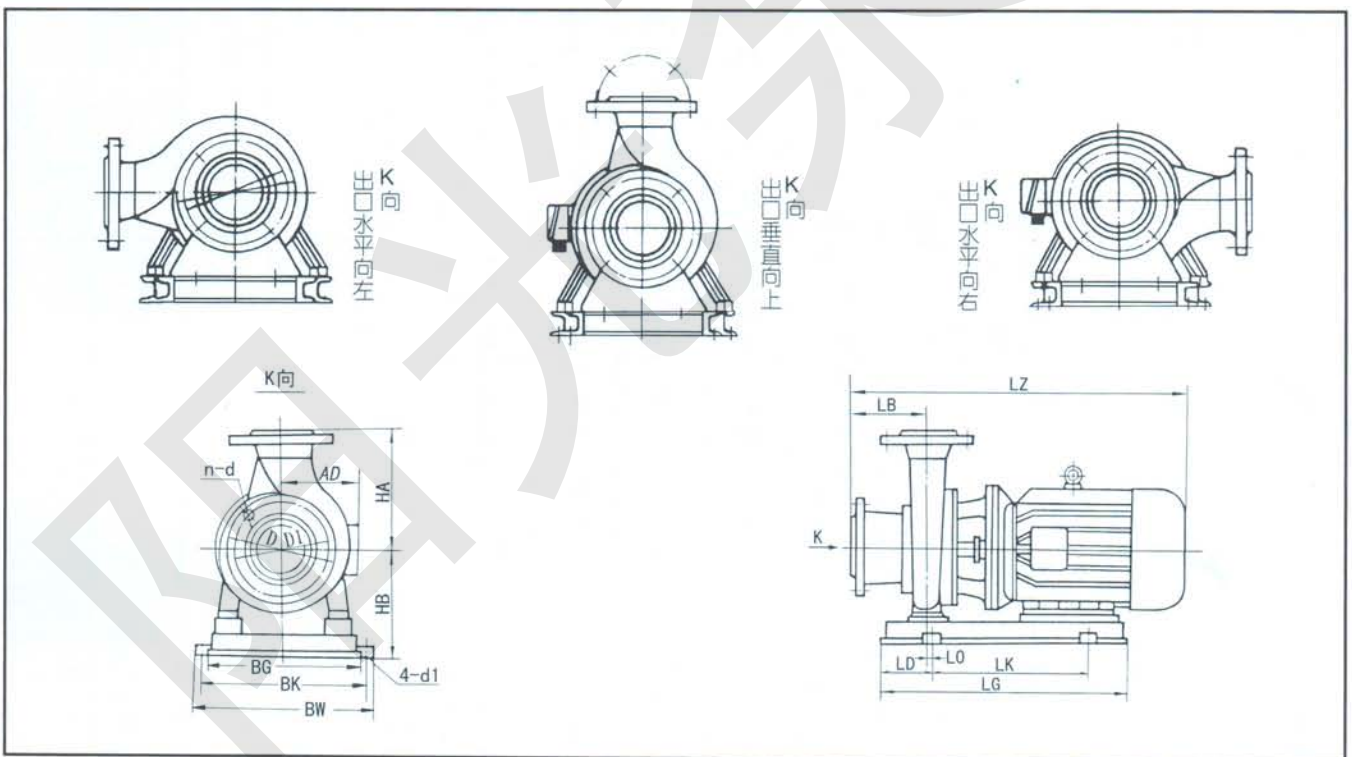

特别说明:

7.5KW以下水泵可配隔震垫直接安装在基础上。

7.5KW以上时, 可与浇筑基础直接安装, 亦可采用我单位IS联接板配合隔震器安装、隔震器的安装方法同ISG泵。

配套的隔震器的尺寸, 与ISG系列中相同规格水泵的隔震器尺寸相同。

泵外形及安装尺寸表

序号	泵型号	电动机		LB	LZ	LO	HB	HA	重量 (kg)	底座号	进出口法兰			
		功率KW	型号								口径	D	D1	n-d
1	40-100	0.55	A02-7112	80	430	30	121	130	49	D37	φ 40	φ 150	φ 110	4-φ 18
2	40-100A	0.37	A02-7112	80	430	30	121	130	49	D37				
3	40-125	1.1	Y802-2	80	462	30	130	150	51	D37				
4	40-125A	0.75	Y801-2	80	422	30	130	150	49	D37				
5	40-160	2.2	Y90L-2	80	498	40	145	170	64	D48				
6	40-160A	1.5	Y90S-2	80	473	40	145	170	59	D48				
7	40-160B	1.1	Y802-2	80	463	30	130	170	50	D37				
8	40-200	4.0	Y112M-2	80	573	40	167	170	92	D48				
9	40-200A	3.0	Y100L-2	80	553	40	155	170	82	D48				
10	40-200B	2.2	Y90L-2	80	503	40	145	170	72	D48				
11	40-250	7.5	Y132S ₂ -2	80	626	45	210	200	132	D53				
12	40-250A	5.5	Y132S ₁ -2	80	626	45	210	200	122	D53				
13	40-250B	4.0	Y112M-2	80	575	40	167	200	86	D48				
14	40-100(I)	1.1	Y802-2	80	460	30	130	145	46	D37				
15	40-100(I)A	0.75	Y801-2	80	420	30	130	145	45	D37				
16	40-125(I)	1.5	Y90S-2	80	473	40	145	150	56	D48				
17	40-125(I)A	1.1	Y802-2	80	463	30	130	150	47	D37				
18	40-160(I)	3.0	Y100L-2	80	552	40	155	160	73	D48				
19	40-160(I)A	2.2	Y90L-2	80	502	40	145	160	64	D48				
20	40-160(I)B	1.5	Y90S-2	80	477	30	145	160	54	D48				
21	40-200(I)	5.5	Y132S ₁ -2	100	645	45	210	180	119	D53				
22	40-200(I)A	4.0	Y112M-2	100	594	40	167	180	89	D48				
23	40-200(I)B	3.0	Y100L-2	100	574	40	155	180	79	D48				
24	40-250(I)	11	Y160M ₁ -2	100	815	50	230	220	189	D74				
25	40-250(I)A	7.5	Y132S ₂ -2	100	657	45	210	220	132	D53				
26	40-250(I)B	7.5	Y132S ₂ -2	100	657	45	210	220	132	D53				
27	40-250(I)C	5.5	Y132S ₁ -2	100	657	45	210	220	116	D53				
28	50-100	1.1	Y802-2	80	460	30	130	150	48	D37				
29	50-100A	0.75	Y801-2	80	420	30	130	150	47	D37				
30	50-125	1.5	Y90S-2	80	473	40	145	150	59	D48				
31	50-125A	1.1	Y802-2	80	463	30	130	150	50	D37				
32	50-160	3.0	Y100L-2	80	552	40	155	160	76	D48				
33	50-160A	2.2	Y90L-2	80	502	40	145	160	67	D48				
34	50-160B	1.5	Y90S-2	80	477	30	145	160	57	D48				
35	50-200	5.5	Y132S ₁ -2	100	645	45	210	180	124	D53				
36	50-200A	4.0	Y112M-2	100	594	40	167	180	93	D48				
37	50-200B	3.0	Y100L-2	100	574	40	155	180	83	D48				
38	50-250	11	Y160M ₁ -2	100	815	50	230	225	194	D74				
39	50-250A	7.5	Y132S ₂ -2	100	657	45	210	225	137	D53				
40	50-250B	7.5	Y132S ₂ -2	100	657	45	210	225	137	D53				
41	50-250C	5.5	Y132S ₁ -2	100	657	45	210	225	129	D53				
42	50-100(I)	1.5	Y90S-2	80	473	40	145	160	58	D48				
43	50-100(I)A	1.1	Y802-2	80	463	30	130	160	47	D37				
44	50-125(I)	3.0	Y100L-2	80	555	40	155	190	72	D48				
45	50-125(I)A	2.2	Y90L-2	80	505	40	145	190	62	D48				
46	50-160(I)	4.0	Y112M-2	80	573	40	167	180	92	D48				
47	50-160(I)A	4.0	Y112M-2	80	573	40	167	180	89	D48				
48	50-160(I)B	3.0	Y100L-2	80	553	40	155	180	79	D48				
49	50-200(I)	7.5	Y132S ₂ -2	100	645	45	210	190	127	D53				
50	50-200(I)A	7.5	Y132S ₂ -2	100	645	45	210	190	125	D53				
51	50-200(I)B	5.5	Y132S ₁ -2	100	645	45	210	190	118	D53				
52	50-250(I)	15.0	Y160M ₂ -2	100	811	50	230	240	216	D74				
53	50-250(I)A	11	Y160M ₁ -2	100	811	50	230	240	206	D74				
54	50-250(I)B	11	Y160M ₁ -2	100	811	50	230	240	204	D74				

泵外形及安装尺寸表

序号	泵型号	电动机		LB	LZ	LO	HB	HA	重量 (kg)	底座号	进出口法兰			
		功率KW	型号								口径	D	D1	n-d
55	50-315(I)	30	Y200L ₁ -2	135	1030	60	290	270	395	D84	φ 50	φ 165	φ 125	4-φ 18
56	50-315(I)A	22	Y180M-2	135	923	60	290	270	336	D84				
57	50-315(I)B	22	Y180M-2	135	899	60	290	270	303	D84				
58	50-315(I)C	15	Y160M ₂ -2	135	854	60	290	270	282	D84				
59	65-100	1.5	Y90S-2	80	473	40	145	160	61	D48				
60	65-100A	1.1	Y802-2	80	463	30	130	160	51	D37				
61	65-125	3.0	Y100L-2	80	555	40	155	180	74	D48				
62	65-125A	2.2	Y90L-2	80	505	40	145	180	64	D48				
63	65-160	4.0	Y112M-2	80	573	40	167	190	94	D48				
64	65-160A	4.0	Y112M-2	80	573	40	167	190	92	D48				
65	65-160B	3.0	Y100L-2	80	553	40	155	190	82	D48				
66	65-200	7.5	Y132S ₂ -2	100	645	45	210	190	130	D53				
67	65-200A	7.5	Y132S ₂ -2	100	645	45	210	190	128	D53				
68	65-200B	5.5	Y132S ₁ -2	100	645	45	210	190	118	D53				
69	65-250	15	Y160M ₂ -2	100	811	50	230	230	224	D74				
70	65-250A	11	Y160M ₁ -2	100	811	50	230	230	212	D74				
71	65-250B	11	Y160M ₁ -2	100	811	50	230	230	210	D74				
72	65-315	30	Y200L ₁ -2	135	1030	60	290	300	403	D84				
73	65-315A	22	Y180M-2	135	923	60	290	300	343	D84				
74	65-315B	22	Y180M-2	135	899	60	290	300	311	D84				
75	65-315C	15	Y160M ₂ -2	135	854	60	290	300	291	D84				
76	65-100(I)	3.0	Y100L-2	100	575	40	155	200	78	D48				
77	65-100(I)A	2.2	Y90L-2	100	525	40	145	200	67	D48				
78	65-125(I)	5.5	Y132S ₁ -2	100	651	45	210	200	123	D53				
79	65-125(I)A	4.0	Y112M-2	100	600	40	167	200	89	D48				
80	65-160(I)	7.5	Y132S ₂ -2	100	647	45	210	200	124	D53				
81	65-160(I)A	7.5	Y132S ₂ -2	100	647	45	210	200	122	D53				
82	65-160(I)B	5.5	Y132S ₁ -2	100	647	45	210	200	112	D53				
83	65-200(I)	15	Y160M ₂ -2	125	815	50	230	215	202	D74				
84	65-200(I)A	11	Y160M ₁ -2	125	815	50	230	215	179	D74				
85	65-200(I)B	7.5	Y132S ₂ -2	125	657	45	210	215	119	D53				
86	65-250(I)	22	Y180M-2	125	909	60	270	240	313	D84				
87	65-250(I)A	18.5	Y160L-2	125	885	50	250	240	242	D74				
88	65-250(I)B	15	Y160M ₂ -2	125	840	50	250	240	223	D74				
89	65-315(I)	37	Y200L ₂ -2	135	1030	60	290	300	426	D84				
90	65-315(I)A	37	Y200L ₂ -2	135	1030	60	290	300	426	D84				
91	65-315(I)B	30	Y200L ₁ -2	135	1030	60	290	300	410	D84				
92	65-315(I)C	22	Y180M-2	135	923	60	290	300	350	D84				
93	80-100	3.0	Y100L-2	100	575	40	155	200	81	D48				
94	80-100A	2.2	Y90L-2	100	525	40	145	200	68	D48				
95	80-125	5.5	Y132S ₁ -2	100	651	45	210	200	123	D53				
96	80-125A	4.0	Y112M-2	100	600	40	167	200	88	D48				
97	80-160	7.5	Y132S ₂ -2	100	647	45	210	200	126	D53				
98	80-160A	7.5	Y132S ₂ -2	100	647	45	210	200	124	D53				
99	80-160B	5.5	Y132S ₁ -2	100	647	45	210	200	115	D53				
100	80-200	15	Y160M ₂ -2	100	815	50	230	225	204	D74				
101	80-200A	11	Y160M ₁ -2	100	815	50	230	225	184	D74				
102	80-200B	7.5	Y132S ₂ -2	100	657	45	210	225	122	D53				
103	80-250	22	Y180M-2	125	909	60	270	250	313	D84				
104	80-250A	18.5	Y160L-2	125	885	50	250	250	244	D74				
105	80-250B	15	Y160M ₂ -2	125	840	50	250	250	224	D74				
106	80-315	37	Y200L ₂ -2	135	1030	60	290	300	428	D84				
107	80-315A	37	Y200L ₂ -2	135	1030	60	290	300	428	D84				
108	80-315B	30	Y200L ₁ -2	135	1030	60	290	300	413	D84				

泵外形及安装尺寸表

序号	泵型号	电动机		LB	LZ	LO	HB	HA	重量 (kg)	底座号	进出口法兰			
		功率KW	型号								口径	D	D1	n-d
109	80-315C	22	Y180M-2	135	923	60	290	300	355	D84	φ 80	φ 200	φ 160	8-φ 18
110	80-100(I)	5.5	Y132S ₁ -2	100	656	45	210	230	126	D53				
111	80-100(I)A	4	Y112M-2	100	605	45	210	230	100	D53				
112	80-125(I)	11	Y160M ₁ -2	100	819	50	230	225	186	D74				
113	80-125(I)A	7.5	Y132S ₂ -2	100	661	45	210	225	124	D53				
114	80-160(I)	15	Y160M ₂ -2	100	819	50	230	250	204	D74				
115	80-160(I)A	11	Y160M ₁ -2	100	819	50	230	250	190	D74				
116	80-160(I)B	11	Y160M ₁ -2	100	819	50	230	250	190	D74				
117	80-200(I)	22	Y180M-2	100	888	60	270	250	303	D84				
118	80-200(I)A	18.5	Y160L-2	100	864	50	250	250	238	D74				
119	80-200(I)B	15	Y160M ₂ -2	100	819	50	250	250	217	D74				
120	80-250(I)	37	Y200L ₂ -2	125	1020	60	290	270	421	D84				
121	80-250(I)A	30	Y200L ₁ -2	125	1020	60	290	270	398	D84				
122	80-250(I)B	30	Y200L ₁ -2	125	1020	60	290	270	398	D84				
123	80-315(I)	75	Y280S-2	125	1236	90	390	315	798	D105				
124	80-315(I)A	55	Y250M-2	125	1160	80	350	315	654	D104				
125	80-315(I)B	45	Y225M-2	125	1073	80	350	315	569	D104				
126	80-315(I)C	37	Y200L ₂ -2	125	1031	80	350	315	506	D104				
127	100-100	5.5	Y132S ₁ -2	100	656	45	210	230	134	D53	φ 100	φ 220	φ 180	8-φ 18
128	100-100A	4	Y112M-2	100	605	45	210	230	107	D53				
129	100-125	11	Y160M ₁ -2	100	819	50	230	225	194	D74				
130	100-125A	7.5	Y132S ₂ -2	100	661	45	210	225	132	D53				
131	100-160	15	Y160M ₂ -2	100	819	50	230	250	214	D74				
132	100-160A	11	Y160M ₁ -2	100	819	50	230	250	199	D74				
133	100-160B	11	Y160M ₁ -2	100	819	50	230	250	196	D74				
134	100-200	22	Y180M-2	100	888	60	270	250	308	D84				
135	100-200A	18.5	Y160L-2	100	864	50	250	250	244	D74				
136	100-200B	15	Y160M ₂ -2	100	819	50	250	250	224	D74				
137	100-250	37	Y200L ₂ -2	125	1020	60	290	270	423	D84				
138	100-250A	30	Y200L ₁ -2	125	1020	60	290	270	403	D84				
139	100-250B	30	Y200L ₁ -2	125	1020	60	290	270	398	D84				
140	100-315	75	Y280S-2	125	1236	90	390	315	800	D105				
141	100-315A	55	Y250M-2	125	1160	80	350	315	664	D104				
142	100-315B	45	Y225M-2	125	1073	80	350	315	574	D104				
143	100-315C	37	Y200L ₂ -2	125	1031	80	350	315	512	D104				
144	125-100	11	Y160M ₁ -2	125	806	50	230	230	234	D74	φ 125	φ 250	φ 210	8-φ 18
145	125-100A	7.5	Y132S ₂ -2	125	685	45	210	230	172	D53				
146	125-125	15	Y160M ₂ -2	125	844	50	230	230	264	D74				
147	125-125A	11	Y160M ₁ -2	125	811	50	230	230	254	D74				
148	125-160	22	Y180M-2	125	913	60	270	260	335	D84				
149	125-160A	18.5	Y160L-2	125	889	50	250	260	274	D74				
150	125-160B	15	Y160M ₂ -2	125	844	50	250	260	254	D74				
151	125-200	37	Y200L ₂ -2	140	1046	60	290	260	473	D84				
152	125-200A	30	Y200L ₁ -2	140	1046	60	290	260	455	D84				
153	125-200B	22	Y180M-2	140	939	60	290	260	395	D84				
154	125-250	55	Y250M-2	140	1175	60	340	300	656	D90				
155	125-250A	45	Y225M-2	140	1088	60	340	300	556	D90				
156	125-250B	37	Y200L ₂ -2	140	1046	60	340	300	495	D84				
157	125-315	90	Y280M-2	140	1301	90	390	360	890	D105				
158	125-315A	75	Y280S-2	140	1251	90	390	360	805	D105				
159	125-315B	75	Y280S-2	140	1251	90	390	360	800	D105				
160	125-315C	55	Y250M-2	140	1175	60	340	360	631	D90				
161	150-200	15	Y160L-4	140	915	40	340	320	326	D83	φ 150	φ 285	φ 240	8-φ 22
162	150-200A	11	Y160M-4	140	870	40	340	320	306	D83				

泵外形及安装尺寸表

序号	泵型号	电动机		LB	LZ	LO	HB	HA	重量 (kg)	底座号	进出口法兰			
		功率KW	型号								口径	D	D1	n-d
163	150-250	18.5	Y180M-4	140	939	40	340	360	366	D83	φ 150	φ 285	φ 240	8-φ 22
164	150-250A	15	Y160L-4	140	915	40	340	360	346	D83				
165	150-250B	11	Y160M-4	140	870	40	340	360	334	D83				
166	150-315	30	Y200L-4	165	1071	40	360	400	476	D83				
167	150-315A	22	Y180L-4	165	1004	40	340	400	406	D83				
168	150-315B	18.5	Y180M-4	165	964	40	340	400	381	D83				
169	150-400	45	Y225M-4	165	1113	60	400	400	587	D87				
170	150-400A	37	Y225S-4	165	1088	60	400	400	547	D87				
171	150-400B	30	Y200L-4	165	1071	40	390	400	513	D84A				
172	150-400C	22	Y180L-4	165	1004	40	390	400	443	D84A				
173	150-250(I)	75	Y280S-2	140	1251	90	390	360	790	D105				
174	150-250(I)A	55	Y250M-2	140	1175	60	340	360	616	D90				
175	150-250(I)B	45	Y225M-2	140	1088	60	340	360	612	D90				
176	150-315(I)	110	Y315S-2	165	1470	100	460	400	1355	D108				
177	150-315(I)A	90	Y280M-2	165	1326	90	390	400	930	D105				
178	150-315(I)B	75	Y280S-2	165	1275	90	390	400	854	D105				
179	200-200	15	Y160L-4	140	915	40	340	345	336	D83				
180	200-200A	11	Y160M-4	140	870	40	340	345	316	D83				
181	200-250	18.5	Y180M-4	140	939	40	340	380	406	D83				
182	200-250A	15	Y160L-4	140	915	40	340	380	376	D83				
183	200-250B	11	Y160M-4	140	870	40	340	380	356	D83				
184	200-315	30	Y200L-4	165	1071	40	360	380	486	D83				
185	200-315A	22	Y180L-4	165	1004	40	340	380	411	D83				
186	200-315B	18.5	Y180M-4	165	964	40	340	380	388	D83				
187	200-400	45	Y225M-4	165	1113	60	400	410	602	D87				
188	200-400A	37	Y225S-4	165	1088	60	400	410	562	D87				
189	200-400B	30	Y200L-4	165	1071	40	390	410	525	D84A				
190	200-400C	22	Y180L-4	165	1004	40	390	410	453	D84A				
191	200-200(I)	22	Y180L-4	160	1004	40	390	380	463	D84A				
192	200-200(I)A	18.5	Y180M-4	160	964	40	390	380	438	D84A				
193	200-250(I)	30	Y200L-4	160	1066	40	390	400	553	D84A				
194	200-250(I)A	22	Y180L-4	160	999	40	390	400	475	D84A				
195	200-250(I)B	18.5	Y180M-4	160	959	40	390	400	448	D84A				
196	200-315(I)	55	Y250M-4	160	1210	80	400	460	779	D104				
197	200-315(I)A	45	Y225M-4	160	1123	60	400	460	654	D87				
198	200-315(I)B	37	Y225S-4	160	1098	60	400	460	614	D87				
199	200-400(I)	75	Y280S-4	165	1291	80	380	460	954	D104				
200	200-400(I)A	75	Y280S-4	165	1291	80	380	460	954	D104				
201	200-400(I)B	55	Y250M-4	165	1215	80	380	460	814	D104				
202	200-400(I)C	45	Y225M-4	165	1128	80	380	460	704	D104				
203	300-235	55	Y280M-6	240	1435	50	540	600	1173	D114				
204	300-235A	45	Y280S-6	240	1385	50	540	600	1116	D114				
205	300-235B	37	Y250M-6	240	1309	50	540	600	988	D114				
206	300-300	75	Y315S-6	240	1579	70	540	650	1590	D125				
207	300-300A	75	Y315S-6	240	1579	70	540	650	1590	D125				
208	300-300B	55	Y280M-6	240	1435	50	540	650	1168	D114				
209	300-380	132	Y315L ₂ -6	240	1690	70	560	700	1900	D125				
210	300-380A	110	Y315L ₁ -6	240	1690	70	560	700	1790	D125				
211	300-380B	90	Y315M-6	240	1620	70	560	700	1720	D125				
212	300-235(I)	160	Y315L ₁ -4	240	1699	70	540	550	1871	D125				
213	300-235(I)A	132	Y315M-4	240	1629	70	540	550	1871	D125				
											φ 300	φ 460	φ 410	12-φ 26

ISW系列泵主要材质及选用

零件名称	材 质
轴	45, 3Cr13, 40Cr, 1Cr18Ni9, 1Cr18Ni9Ti
泵 体	HT200, HT250, ZG25II, ZG1Cr13, ZG1Cr18Ni9, Cr18Ni9Ti
叶 轮	HT200, HT250, ZG25II, ZC1Cr13, ZG1Cr18Ni9, ZH62, ZCuSn10P1

	静环材料	动环材料	结 构 件	橡 胶 件	弹 簧
机械密封主要材料 (根据介质选用)	碳化钨(WC)	碳化钨(WC)	H62黄铜	丁腈橡胶 氟橡胶	65Mn镀铬
	碳化硅(SiC)	碳化硅(SiC)			
	氮化硅(Si ₃ N ₄)	氮化硅(Si ₃ N ₄)	1Cr18Ni9Ti	四氟封圈	1Cr18Ni9Ti
	氧化铝陶瓷	氧化铝陶瓷			
石 墨	石 墨				

安 装 说 明

- 1、安装前应检查机组紧固件有无松动现象，泵体流道有无异物堵塞，以免水泵运行时损坏叶轮和泵体。
- 2、安装时管道重量不应加在水泵上，以免使泵变形。
- 3、安装时必须拧紧地脚螺栓，以免起动时振动对泵性能的影响。
- 4、为了维修方便和使用安全，在泵的进出口管路上各安装一只调节阀及在泵出口附近安装一只压力表，以保证在额定扬程和流量范围内运行，确保泵正常运行，增长水泵的使用寿命。
- 5、安装后拨动泵轴，叶轮应无磨擦声或卡死现象，否则应将泵拆开检查原因。
- 6、泵分硬性联接安装和柔性联接安装两种(见联接方式)。

底座编号及电动机接线盒安装尺寸

底座编号及安装尺寸

底座号	LD	LK	LG	BG	BK	BW	d1
D37	90	190	370	195	225	255	15
D48	110	260	480	275	305	335	15
D53	120	290	530	320	350	400	20
D74	130	480	740	370	400	450	24
D84	140	500	840	450	470	520	20
D90	150	600	900	530	560	610	20
D105	180	690	1050	590	630	690	24
D83	130	570	830	490	520	570	20
D84A	140	560	840	540	570	620	20
D87	170	520	870	590	630	680	24
D104	170	600	1040	590	630	690	24
D114	190	760	1140	690	730	790	24
D125	210	830	1250	790	830	890	24
D108	180	720	1080	690	730	790	24

电动机接线盒尺寸

电动机机座号	AD	电动机机座号	AD
Y80	150	Y180L	285
Y90S	160	Y200L	315
Y90L	160	Y225S	345
Y100L	180	Y225M	345
Y112M	190	Y250M	385
Y132S	210	Y280S	410
Y132M	210	Y280M	410
Y160M	265	Y315S	576
Y160L	265	Y315M	576
Y180M	285	Y315L	576

起动与停车

起动前准备:

- 1、试验电机转向是否正确，从电机顶部往泵看为顺时针旋转，试验时间要短，以免使机械密封干磨损。
- 2、打开排气阀使液体充满整个泵体，待满后关闭排气阀。
- 3、检查各部位是否正常。
- 4、用手盘动泵以使润滑油进入机械密封端面。
- 5、高温型应先进行预热，升温速度50°C/小时，以保证各部受热均匀。

起 动:

- 1、全开进口阀门。
- 2、关闭吐出管路阀门。
- 3、起动电机，观察泵运行是否正确。
- 4、调节出口阀开度以所需工况，如用户在泵出口处装有流量计或压力表，应通过调节出口阀门开度使泵在性能参数表所列的额定点上运转，如用户在泵出口处装有流量计或压力表，应通过调节出口阀门开度，测量泵的电机电流，使电机在额定电流内运行，否则将造成泵超负荷运行(即大电流运行)至使电机烧坏。调正好的出口阀门开启大与小和管道工况有关。
- 5、检查轴封泄漏情况，正常时机械密封泄漏应小于3滴/分。
- 6、检查电机、轴承处温升 $\leq 70^{\circ}\text{C}$ 。

停 车:

- 1、高温型先降温，降温速度 $< 10^{\circ}\text{C}/\text{分}$ ，把温度降低到80°C以下，才能停车。
- 2、关闭吐出管路阀门。
- 3、停止电机。
- 4、关闭进口阀门。
- 5、如长期停车，应将泵内液体放尽。

泵的维护

1、运行中的维护:

(1)进口管道必须充满液体,禁止泵在汽蚀状态下长期运行。(2)定时检查电机电流值,不得超过电机额定电流。(3)泵进行长期运行后,由于机械磨损,使机组噪音及振动增大时,应停车检查,必要时可更换易损零件及轴承,机组大修期一般为一年。

2、机械密封维护:

(1)机械密封润滑应清洁无固体颗粒。(2)严禁机械密封在干磨情况下工作。(3)起动前应先盘动泵(电机)几圈,以免突然起动造成石墨环断裂损坏。(4)密封泄漏量允差3滴/分。否则应检查。

主要材质及选用

ISW ISWR 型清水泵 ISWG		材料		零件名称	泵 体	叶 轮	泵 盖	泵体座	轴	叶轮螺母
		温度-20℃~+120℃		HT200	HT200	HT200	HT200	45	2Cr13	
		温度-45℃~+240℃		ZG25	ZG25	ZG25	ZG25	35CrMo	2Cr13	
ISWB型油泵	I	不含腐蚀性 -20℃~+120℃		HT200	HT250	HT200	HT200	45	2Cr13	
	II	不含腐蚀性 -45℃~+240℃		ZG25	ZG25	25	ZG25	35CrMo	2Cr13	
	III	不含腐蚀性 -45℃~+240℃		305	305	305	305	3Cr13	2Cr13	
ISWH型化工泵材质及代号表 (根据用户要求选用)		材 质	ZG1Cr18Ni9	ZG1Cr18Ni9	ZG0Cr18Ni12M02Ti	ZG1Cr18Ni12M02Ti				
		代 号	303	305	306	307				
机械密封主要材料 (根据用户要求选用)		静环材料		动环材料		结 构 件	橡 胶 件	弹 簧		
		碳化钨(WC) 碳化硅(SiC) 氮化硅(Si3N4) 氧化铝陶瓷 石 墨		碳化钨(WC) 碳化硅(SiC) 氮化硅(Si3N4) 氧化铝陶瓷 石 墨		H62黄铜 1Cr18Ni19Ti	丁腈橡胶 氟 橡 胶 四氟封川	65Mn镀铬 1Cr18Ni19Ti		

易 损 件 (机械密封和轴承)

电 机 功 率	机械密封规格	轴 承 规 格
0.25、0.37KW	CF01-14	180202
0.55、0.75、1.1KW	CF01-18	180204
1.5、2.2KW	CF01-20	180205
3KW	CF01-25	180206
4KW	CF01-25	180306
5.5、7.5KW(2极)	CF01-30	180308
7.5KW(4极)	CF01-35	180308
11、15(2、4极)18.5KW(2极)	CF01-35	46309、180308
18.5(4极)、22KW(2、4极)	CF01-40	46311、180310
30KW(2、4极)、37KW(2极)	CF01-45	46312、180311
34KW(4极)、45KW(2、4极)	CF01-45	46313、180312
55KW(2、4极)	CF01-55	46314、180313
75KW(2、4极)90KW(2、4极)	CF01-55	46317、180316

故障原因及排除方法

故障现象	可能产生的原因	排除方法
1. 水泵不出水	<ul style="list-style-type: none"> a. 进出口阀门未打开, 进出管路阻塞, 流道叶轮阻塞 b. 电机运行方向不对, 电机缺相转速很慢 c. 吸入管漏气 d. 泵没灌满液体, 泵腔内有空气 e. 进口供水不足, 吸程过高, 底阀漏水 f. 管路阻力过大, 泵选型不当 	<ul style="list-style-type: none"> a. 检查, 去除阻塞物 b. 调整电机方向, 紧固电机接线 c. 拧紧各密封面, 排除空气 d. 打开泵上盖或打开排气阀, 排尽空气 e. 停机检查、调整(并网自来水管和带吸程使用易出现此现象) f. 减少管路弯道, 重新选泵
2. 水泵流量不足	<ul style="list-style-type: none"> a. 先按1.原因检查 b. 管道、泵流道叶轮部分阻塞, 水垢沉积、阀门开度不足 c. 电压偏低 d. 叶轮磨损 	<ul style="list-style-type: none"> a. 先按1.排除 b. 去除阻塞物, 重新调整阀门开度 c. 稳压 d. 更换叶轮
3. 功率过大	<ul style="list-style-type: none"> a. 超过额定流量使用 b. 吸程过高 c. 泵轴承磨损 	<ul style="list-style-type: none"> a. 调节流量关小出口阀门 b. 降低 c. 更换轴承
4. 杂音振动	<ul style="list-style-type: none"> a. 管路支撑不稳 b. 液体混有气体 c. 产生汽蚀 d. 轴承损坏 e. 电机超载发热运行 	<ul style="list-style-type: none"> a. 稳固管路 b. 提高吸入压力排气 c. 降低真空度 d. 更换轴承 e. 调整按5.
5. 电机发热	<ul style="list-style-type: none"> a. 流量过大, 超载运行 b. 碰擦 c. 电机轴承损坏 d. 电压不足 	<ul style="list-style-type: none"> a. 关小出口阀 b. 检查排除 c. 更换轴承 d. 稳压
6. 水泵漏水	<ul style="list-style-type: none"> a. 机械密封磨损 b. 泵体有砂孔或破裂 c. 密封面不平整 d. 安装螺栓松懈 	<ul style="list-style-type: none"> a. 更换 b. 焊补或更换 c. 修整 d. 紧固

管路损耗参考表

管径 (mm)	流 量 (L/S)									
	1	2	4	6	8	10	15	20	25	30
25	3.27	13.0								
38	3.5	14	55				15	20		
50	0.8	3.1	13	29						
65		0.8	3.2	7.1	13	20	40	50		
75		0.4	1.6	3.3	5.9	9.6	21.6	60	70	
100			0.4	0.8	1.3	2.1	6.8	8.6	13	19.4
125				0.23	0.4	0.63	1.3	2.7	4.1	5.9
150					0.16	0.26	0.58	1.1	1.6	2.3
175						0.11	0.27	0.5	0.74	1.05
200							0.13	0.26	0.37	0.53
250								0.07	0.12	0.18
300								0.07	0.12	0.19
								0.27	0.37	0.49
								0.68	0.93	1.2
								1.5	2.1	2.9
								3.7	4.7	6.1
								7.7	9.6	12.5
								10.7	13.6	17.5
								14.5	18.4	23.3
								19.4	24.3	30.3
								25.3	31.3	39.3
								31.3	39.3	49.3
								39.3	49.3	61.3
								49.3	61.3	76.3
								61.3	76.3	96.3
								76.3	96.3	121.3
								96.3	121.3	151.3
								121.3	151.3	191.3
								151.3	191.3	241.3
								191.3	241.3	301.3
								241.3	301.3	371.3
								301.3	371.3	461.3
								371.3	461.3	571.3
								461.3	571.3	701.3
								571.3	701.3	871.3
								701.3	871.3	1081.3
								871.3	1081.3	1341.3
								1081.3	1341.3	1661.3
								1341.3	1661.3	2041.3
								1661.3	2041.3	2501.3
								2041.3	2501.3	3051.3
								2501.3	3051.3	3751.3
								3051.3	3751.3	4601.3
								3751.3	4601.3	5651.3
								4601.3	5651.3	6951.3
								5651.3	6951.3	8551.3
								6951.3	8551.3	10601.3
								8551.3	10601.3	13201.3
								10601.3	13201.3	16401.3
								13201.3	16401.3	20201.3
								16401.3	20201.3	25201.3
								20201.3	25201.3	31201.3
								25201.3	31201.3	38201.3
								31201.3	38201.3	47201.3
								38201.3	47201.3	58201.3
								47201.3	58201.3	72201.3
								58201.3	72201.3	89201.3
								72201.3	89201.3	110201.3
								89201.3	110201.3	136201.3
								110201.3	136201.3	167201.3
								136201.3	167201.3	204201.3
								167201.3	204201.3	254201.3
								204201.3	254201.3	314201.3
								254201.3	314201.3	384201.3
								314201.3	384201.3	474201.3
								384201.3	474201.3	584201.3
								474201.3	584201.3	724201.3
								584201.3	724201.3	894201.3
								724201.3	894201.3	1104201.3
								894201.3	1104201.3	1364201.3
								1104201.3	1364201.3	1674201.3
								1364201.3	1674201.3	2044201.3
								1674201.3	2044201.3	2544201.3
								2044201.3	2544201.3	3144201.3
								2544201.3	3144201.3	3844201.3
								3144201.3	3844201.3	4744201.3
								3844201.3	4744201.3	5844201.3
								4744201.3	5844201.3	7244201.3
								5844201.3	7244201.3	8944201.3
								7244201.3	8944201.3	11044201.3
								8944201.3	11044201.3	13644201.3
								11044201.3	13644201.3	16744201.3
								13644201.3	16744201.3	20444201.3
								16744201.3	20444201.3	25444201.3
								20444201.3	25444201.3	31444201.3
								25444201.3	31444201.3	38444201.3
								31444201.3	38444201.3	47444201.3
								38444201.3	47444201.3	58444201.3
								47444201.3	58444201.3	72444201.3
								58444201.3	72444201.3	89444201.3
								72444201.3	89444201.3	110444201.3
								89444201.3	110444201.3	136444201.3
								110444201.3	136444201.3	167444201.3
								136444201.3	167444201.3	204444201.3
								167444201.3	204444201.3	254444201.3
								204444201.3	254444201.3	314444201.3
								254444201.3	314444201.3	384444201.3
								314444201.3	384444201.3	474444201.3
								384444201.3	474444201.3	584444201.3
								474444201.3	584444201.3	724444201.3
								584444201.3	724444201.3	894444201.3
								724444201.3	894444201.3	1104444201.3
								894444201.3	1104444201.3	1364444201.3
								1104444201.3	1364444201.3	1674444201.3
								1364444201.3	1674444201.3	2044444201.3
								1674444201.3	2044444201.3	2544444201.3
								2044444201.3	2544444201.3	3144444201.3
								2544444201.3	3144444201.3	3844444201.3
								3144444201.3	3844444201.3	4744444201.3
								3844444201.3	4744444201.3	5844444201.3
								4744444201.3	5844444201.3	7244444201.3
								5844444201.3	7244444201.3	8944444201.3
								7244444201.3	8944444201.3	11044444201.3
								8944444201.3	11044444201.3	13644444201.3
								11044444201.3	13644444201.3	16744444201.3
								13644444201.3	16744444201.3	20444444201.3
								16744444201.3	20444444201.3	25444444201.3
								20444444201.3	25444444201.3	31444444201.3
								25444444201.3	31444444201.3	38444444201.3
								31444444201.3	38444444201.3	47444444201.3
								38444444201.3	47444444201.3	58444444201.3
								47444444201.3	58444444201.3	72444444201.3
								58444444201.3	72444444201.3	89444444201.3
								72444444201.3	89444444201.3	110444444201.3
								89444444201.3	110444444201.3	136444444201.3
								110444444201.3	136444444201.3	167444444201.3
								136444444201.3	167444444201.3	204444444201.3
								167444444201.3	204444444201.3	254444444201.3
								204444444201.3	254444444201.3	314444444201.3
								254444444201.3	314444444201.3	384444444201.3
								314444444201.3	384444444201.3	474444444201.3
								384444444201.3	474444444201.3	584444444201.3
								474444444201.3	584444444201.3	724444444201.3
								584444444201.3	724444444201.3	894444444201.3
								724444444201.3	894444444201.3	1104444444201.3
								894444444201.3	1104444444201.3	1364444444201.3
								1104444444201.3	1364444444201.3	1674444444201.3
								1364444444201.3	1674444444201.3	2044444444201.3
								1674444444201.3	2044444444201.3	2544444444201.3
								2044444444201.3	2544444444201.3	3144444444201.3
								2544444444201.3	3144444444201.3	3844444444201.3
								3144444444201.3	3844444444201.3	4744444444201.3
								3844444444201.3	4744444444201.3	5844444444201.3
								4744444444201.3	5844444444201.3	7244444444201.3
								5844444444201.3	7244444444201.3	8944444444201.3
								7244444444201.3	894444	

阳光复业



上海阳光泵业制造有限公司

SHANGHAI YANGGUANG PUMP MFG.CO.,LTD.

地 址：上海市金山区兴塔经济开发区

电 话：021-66528888 66521111 66525619